

# SPECTRUM 400

## Category I Appliance

Must be vented into a negative pressure vent system.

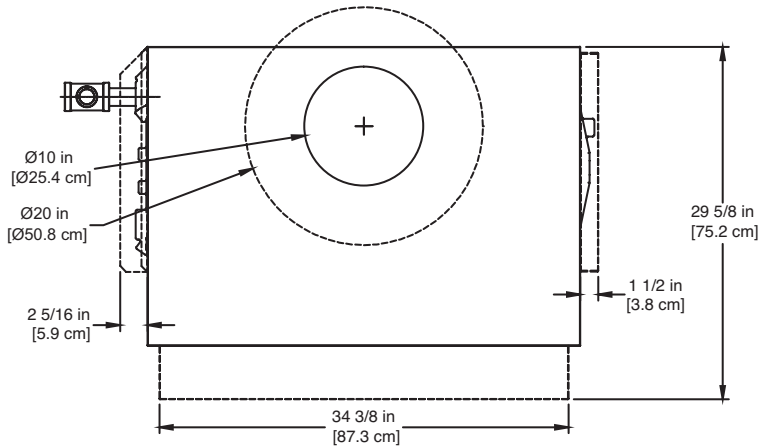

TOP

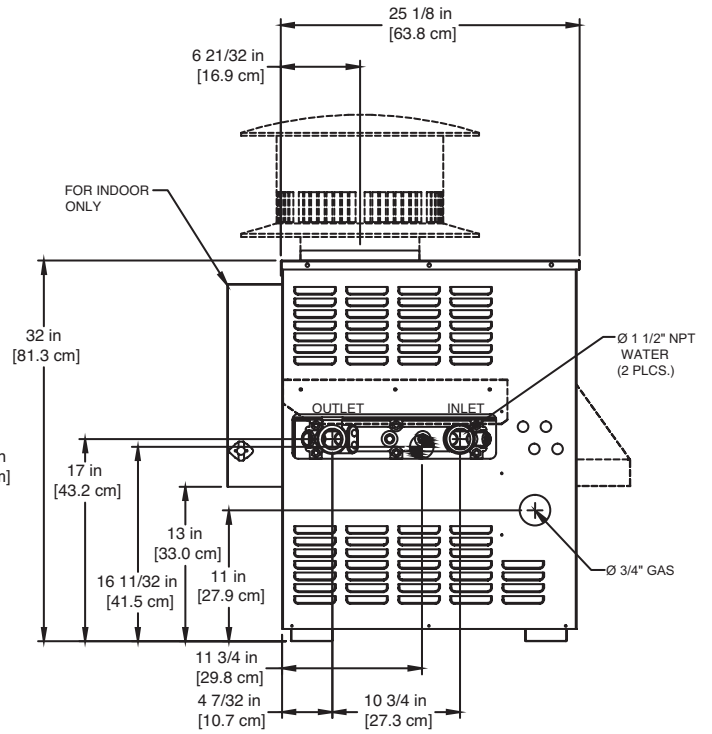

LEFT SIDE

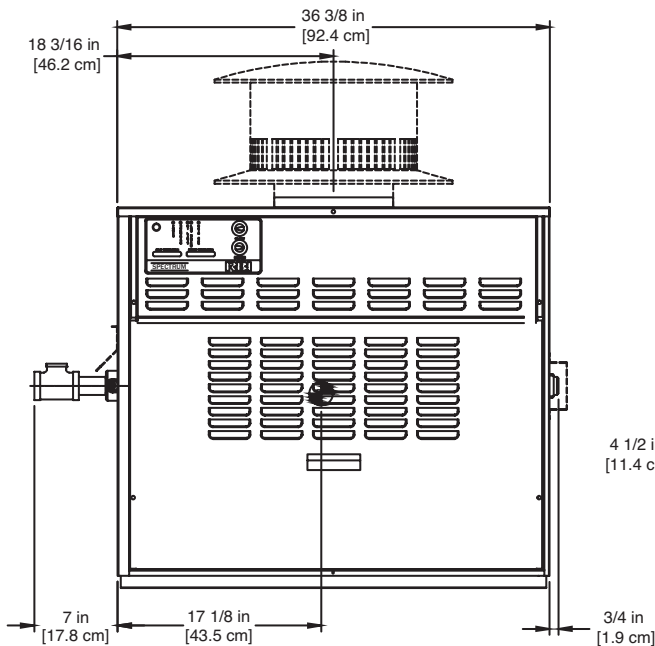

FRONT

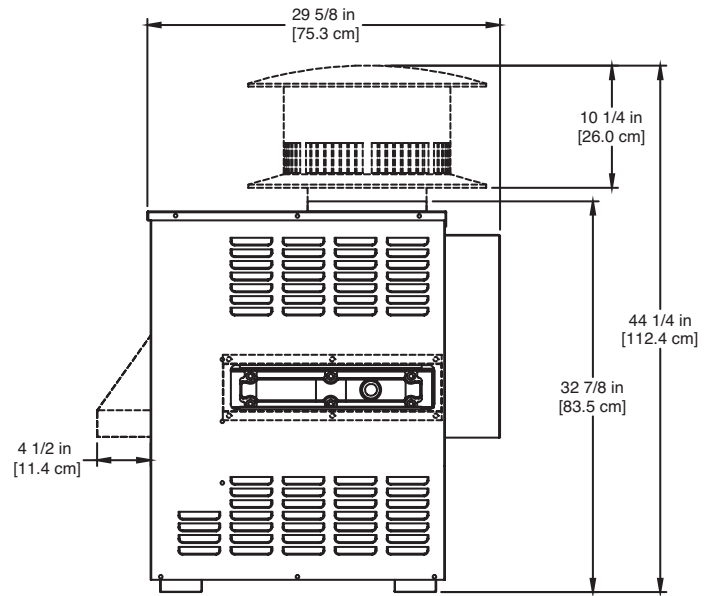

RIGHT SIDE

NOTE:  
----- FOR OUTDOOR ONLY

RSUB-7-C

### Notes:

1. Dimensions are approximate and should not be used to "rough-in" equipment.
2. Dimensions are subject to change without notice.

## BOILER CERTIFIED RATINGS & CAPACITIES

<b>Fuel Type</b>	Natural/Propane Gas	<b>Boiler FLA</b>	1*
<b>Input BTU/hr.</b>	399,000 / 117 kW	<b>Min. Gas Pressure Required</b>	5" WC**
<b>Output BTU/hr.</b>	323,988 / 95 kW	<b>Max. Gas Pressure Allowed</b>	14" WC
<b>Electrical Requirements</b>	120VAC / 1 ph / 60 hz	<b>Operating Weight</b>	264 lbs. / 120 kg.

## BOILER / WATER HEATER TRIM & CONTROLS

<b>Gas Valve - INT</b>	Honeywell VR8304M 3/4"	<b>Ignition Control (SB On/Off)</b>	Honeywell S9361A2085
<b>Gas Valve</b>	Honeywell VR8304Q 3/4"- 2 Stg	<b>Ignition Control (SB 2 Stg.)</b>	Honeywell S86IOM
<b>Gas Valve</b>	Honeywell VR8304Q 3/4"- 2 Stg.	<b>Ignition Control (SW)</b>	Honeywell S86IOM
<b>Operating Control (SB)</b>	Jumo - 2 Stage	<b>Relief Valve - SW</b>	3/4" x 3/4" set @ 125 psi
<b>High Limit (SB/SW)</b>	Jumo	<b>Relief Valve - SB</b>	3/4" x 3/4" set @ 30 psi
		<b>Flow Switch</b>	TACO

## A.S.M.E.

<b>ASME Sect IV Htg Surface</b>	54.3 Sq. Ft. / 5.04 Sq. M.	<b>Design Data</b>	Max. 160 psig & 250°F
<b>Water Volume</b>	1.5 gal / 5.64 Liters		

\* Add circulator amps.

\*\* For incoming gas pressures lower than 5" WC natural or 11" WC propane, consult factory.

## BOILER TEMPERATURE RISE / PRESSURE DROP

10°F / 5.5°C				20°F / 11.1°C				30°F / 16.7°C				
Flow Rate		Pressure Drop		Flow Rate		Pressure Drop		Flow Rate		Pressure Drop		
GPM	L/s	Ft	kPa	GPM	L/s	Ft	kPa	GPM	L/s	Ft	kPa	
64.8	4.1	1.69	5.0	32.4	2.0	0.47	1.4	21.6	1.4	0.20	0.7	<b>2 Pass</b>
-	-	-	-	32.4	2.0	3.40	10.0	21.6	1.4	1.60	4.7	<b>4 Pass</b>

## WATER HEATER HOURLY RECOVERY CAPACITY (GPH & LPH)

40°F	22°C	60°F	33°C	80°F	44°C	100°F	56°C	120°F	67°C	140°F	78°C
960	3630	640	2420	480	1815	384	1452	320	1210	274	1037

**REP FIRM** \_\_\_\_\_  
**SUBMITTED BY** \_\_\_\_\_  
**JOB NAME** \_\_\_\_\_  
**ARCHITECT** \_\_\_\_\_  
**ENGINEER** \_\_\_\_\_  
**CONTRACTOR** \_\_\_\_\_  
**DATE** \_\_\_\_\_

# SPECTRUM 400

### Category I Appliance

Must be vented into a negative pressure vent system.



A Division of Mestek, Inc.  
 Westfield, MA 01085  
 (413) 564-5515